



# HELUKABEL®

HELUKABEL® GmbH, Hemminge - Germany

Technisches Datenblatt – Technical Data Sheet – Technisches Datenblatt – Technical Data Sheet – Technisches Datenblatt – Technical Data Sheet

## Singlemode SC/SC duplex adaptor metal housing , ceramic sleeve , with dust cap

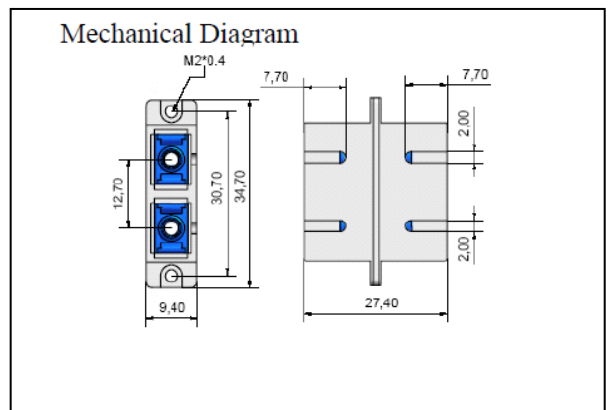
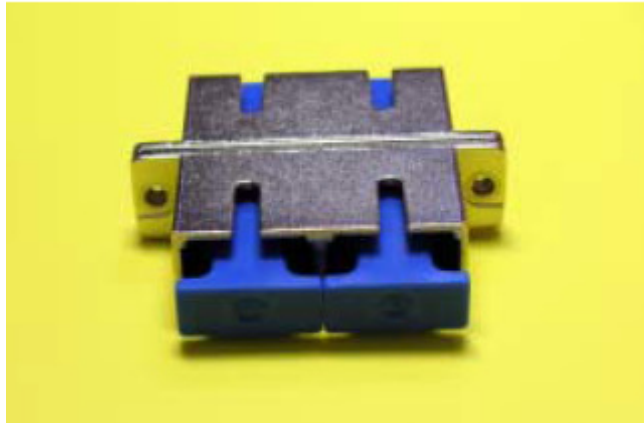

The performance of the adaptors has been carefully designed to meet the toughest Telcorda standards  
**ETIA-455 , GR-326-CORE**

in the tests of:

- OPTICAL CHARACTERISTICS
- VIBRATION TEST
- THERMAL CYCLING
- IMPACT RESISTANCE
- SALT SPRAY EROSION
- THERMAL AGING
- HUMIDITY RESISTANCE
- OTHERS

### Specification

Item	Adaptors
Sleeve Material	Ceramic
Typical Insertion Loss	0.2dB
Operating Temperature	-40°C/ +75°C
Storage Temperature	-55°C/ +85°C

Weiliegabe an Dritte nur mit Genehmigung der HELUKABEL GmbH - Alle Rechte vorbehalten -  
Transfer to third party only by authority of the HELUKABEL GmbH

HELUKABEL GmbH Phone: +49-7150-9209-0 Fax: +49-7150-970819 Internet: www.helukabel.de

Date of issue : 02.12.2014

Technical modification reserved

Creator : DNB / Berger PM

Number : 805111

Up-dating : 16.12.2014 Name: Berger Page 1 / 1



# HELUKABEL®

HELUKABEL® GmbH, Hemminge - Germany

Technisches Datenblatt – Technical Data Sheet – Technisches Datenblatt – Technical Data Sheet – Technisches Datenblatt – Technical Data Sheet

## Singlemode SC/SC duplex adaptor metal housing , ceramic sleeve , with dust cap

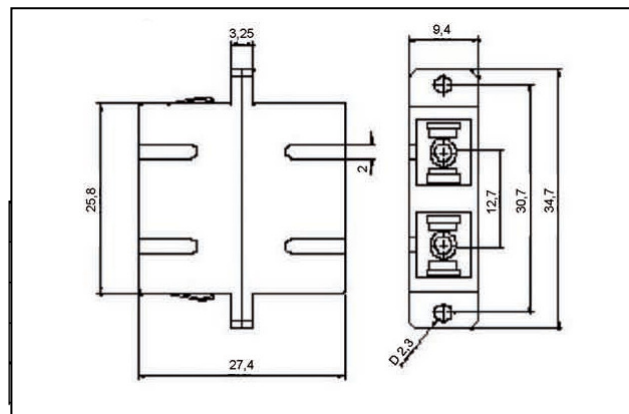
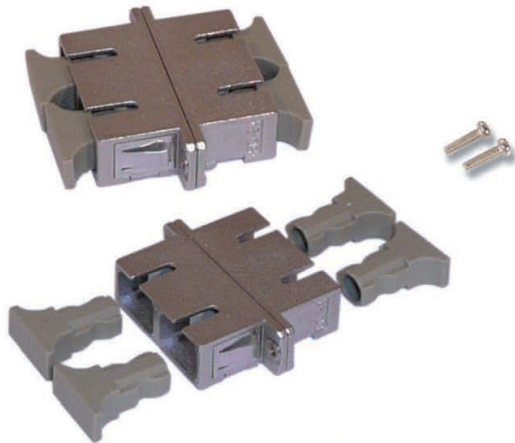

### Specifications:

- Multimode
- Housing material: metal
- Sleeve material: ceramic
- Insertion Loss (typ.): 0.2 dB
- Temperature range: -40°C ~ +75°C (operating)  
-55°C ~ +85°C (storage)
- Including 2 Screws M2 x 6.2

The performance of the adapters has been carefully designed to meet the toughest Telcordia standards EIA-455, GR-326-CORE in the tests of:

- Optical characteristics
- Vibration test
- Thermal cycling
- Impact resistance
- Salt spray erosion
- Thermal aging
- Humidity resistance

RoHS  
compliant

HELUKABEL GmbH

Phone: +49-7150-9209-0

Fax: +49-7150-970819

Internet: [www.helukabel.de](http://www.helukabel.de)

Date of issue : 02.12.2014

Technical modification reserved

Creator : DNB / Berger PM

Number : 805112

Up-dating : 16.12.2014 Name: Berger Page 1 / 1